

CAD FILE:

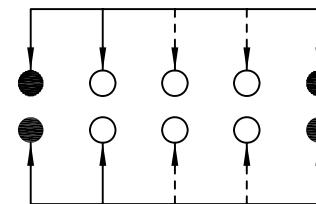

SCHEMATIC (NON-SHORTING)

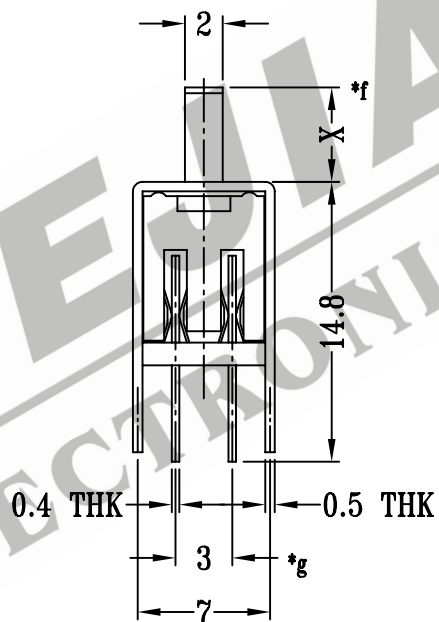
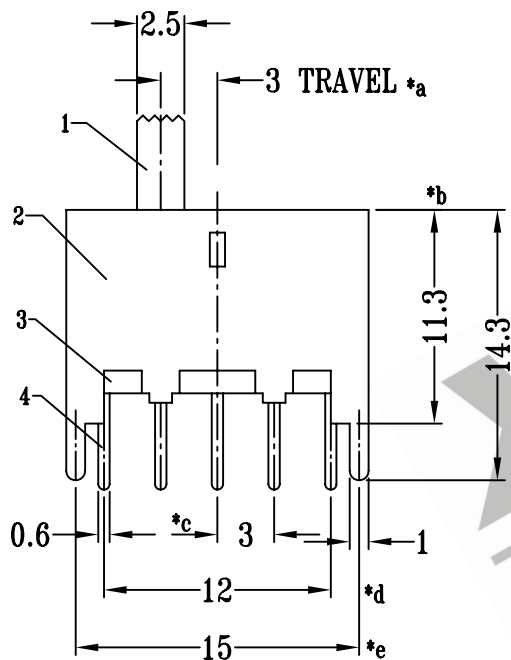
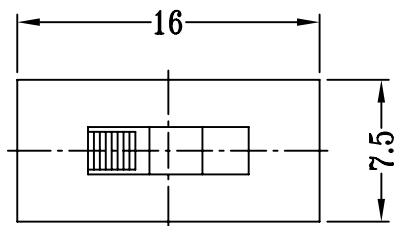
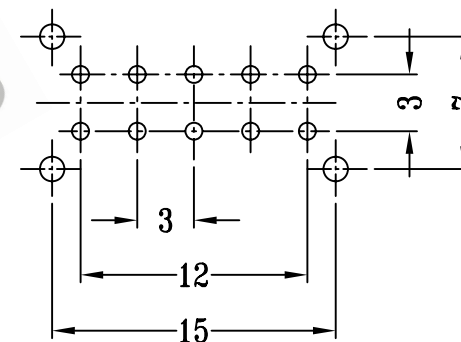

P.C.B LAYOUT

注：“\*”表示关键尺寸（7个）

NO.	PARTS	MATERIALS	Q'TY	FINISH	TOLERANCE UNLESS SPECIFIED	SHENZHEN XIEJIA ELECTRONICS CO.,LTD.				
8						ISSUE	DATE	DESCRIPTIONS OF REVISION		APPD.
7	STEEL BALL	STEEL	2	NATURAL	WITHIN: 1.5±0.1mm OVER: 1.5±0.2mm					
6	SPRING	STEEL WIRE	1	TEMPER						
5	CONTACT CLIP	PBS	2	Ag CLAD						
4	TERMINAL	BRASS STRIP	8	Ag PLATED OVER Ni PLATED	TITLE : VERTICAL SLIDE SWITCH	UNIT : mm	DRWG NO.: XJ-DR-SS23F31-00			
3	BASE	PHENOLIC RESIN	1	NATURAL	MODEL: SS-23F31	SCALE: 5:2	DWN.	ZHOUYU	2004-7-16	
2	FRAME	STEEL STRIP	1	Ni PLATED			CHK'D	FANGYING	2004-7-16	
1	KNOB	POM	1	BLACK	ALL MATERIALS MUST BE COMPLIANT TO ROHS		APPD.	KANGXINAN	2004-7-16	